

PRODUCT BULLETIN

PB NO. 115
Rev. 2

Subject:

**Medium Compression Ratio (8.20:1) “Heavy”
Power Piston for Superior Natural Gas Engines**

In order to meet customer requirements for pistons supplied in newer production Superior Gas Engines, **EnDyn** is pleased to announce the availability of an improved medium compression ratio (8.20:1) power piston. The new “heavy” piston (P-034-506) has increased strength in the crown and piston ring areas. These areas have presented problems on earlier OEM pistons.

The “heavy” piston can be easily identified by a notch cut in the skirt end of the piston, as shown in Figure 1, as well as the part number being stamped on the crown of the piston.

In order to maintain the unbalanced forces and couples in the engine (maximum piston variation of 1 lb.), the end-user must replace the complete engine set because of the increased piston weight, if not already equipped with the P-034-506 pistons. (P-034-506 is 2.4 lbs. heavier than the P-029-528 piston).

However, for those customers who have the P-029-528 medium compression ratio piston in their engines and do not wish to change out a complete set, **EnDyn** will continue to offer this piston as a normal stocking item complete with the standard **PowerParts**[®] two (2) year warranty.

For further information, price, and availability, please contact **EnDyn** or your local **EnDyn PowerParts**[®] distributor.

4-26-11

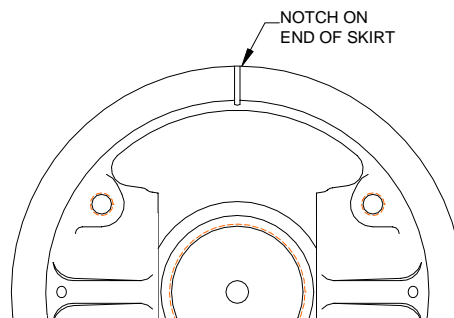

Figure 1

Marketing Dept.
300 West First
Alice, Texas 78332 USA
361.668.8311
800.723.6396
fax 361.668.3906