



# TECHNICAL BULLETIN

TB NO. 1042

Rev. 0

**Subject:** Fresh-Air Waste-gate Conversions for Superior Cleanburn Engines

**Problem:** Customers continue to experience problems with the existing exhaust waste-gate valves on Superior cleanburn engines. The problems are directly related to the constant exposure to the high exhaust temperatures ranging from 900° F to 1150° F, dependent on RPM and Load.

EnDyn developed the original cleanburn conversion kits for the existing Superior turbocharged engines during 1988. Since the engines were equipped with water-cooled exhaust manifolds, it was necessary to install a fresh-air waste-gate upstream of the intercoolers to control air/fuel ratios and exhaust emissions. The excess air was vented into the exhaust piping downstream of the turbocharger. Since the waste-gates are only exposed to fresh-air at temperatures of 150 to 200 degrees, we experience excellent reliability and longer life of the waste-gate valves and internal components. Based on numerous request, EnDyn has developed conversion kits for both the "inline" and "VEE" series Superior engines. These are proven systems which can be utilized with your existing air/fuel controls.

For layout and the required B.O.M., refer to EnDyn drawings P-033-023-Y-4 and P-033-023-V-5.

If you need additional copies, have any questions or require additional information, please contact **EnDyn's** Technical Service Department or your local **PowerParts**® Distributor or **EnDyn** Field Sales Representative.

Technical Service Dept.  
300 West First  
Alice, Texas 78332 USA  
361.668.8311  
800.723.6396  
fax 361.668.3906

**BILL OF MATERIALS**

ITEM	DESCRIPTION	QTY.	PART NUMBER
1.	CAPSCREWS	8	P-01CG1248PC
2.	NUT-HEX FULL	8	P-01HW1200PC
3.	LOCKWASHER	8	P-01LW1200PC
4.	FLANGE	2	P-01FA40015
5.	HOSE ASSY.	1	P-031-125-V-5-1
6.	HOSE ASSY.	1	P-031-125-V-5-2
7.	GASKET	2	P-033-023-X-5
8.	WASTE GATE	1	P-11NA4021SP
9.	PIPE	3	P-217A400FC
10.	COLLAR 5"-THREADED	3	P-217A400FC
11.	THREADED TEE	1	P-217A400FC
12.	HEX UNION	2	P-317A400SS

NOTE:  
 - WELD ITEM #10 IN APPROX. POSITIONS SHOWN (3 REQ'D)  
 - MINIMAL FIELD WELDING REQ'D

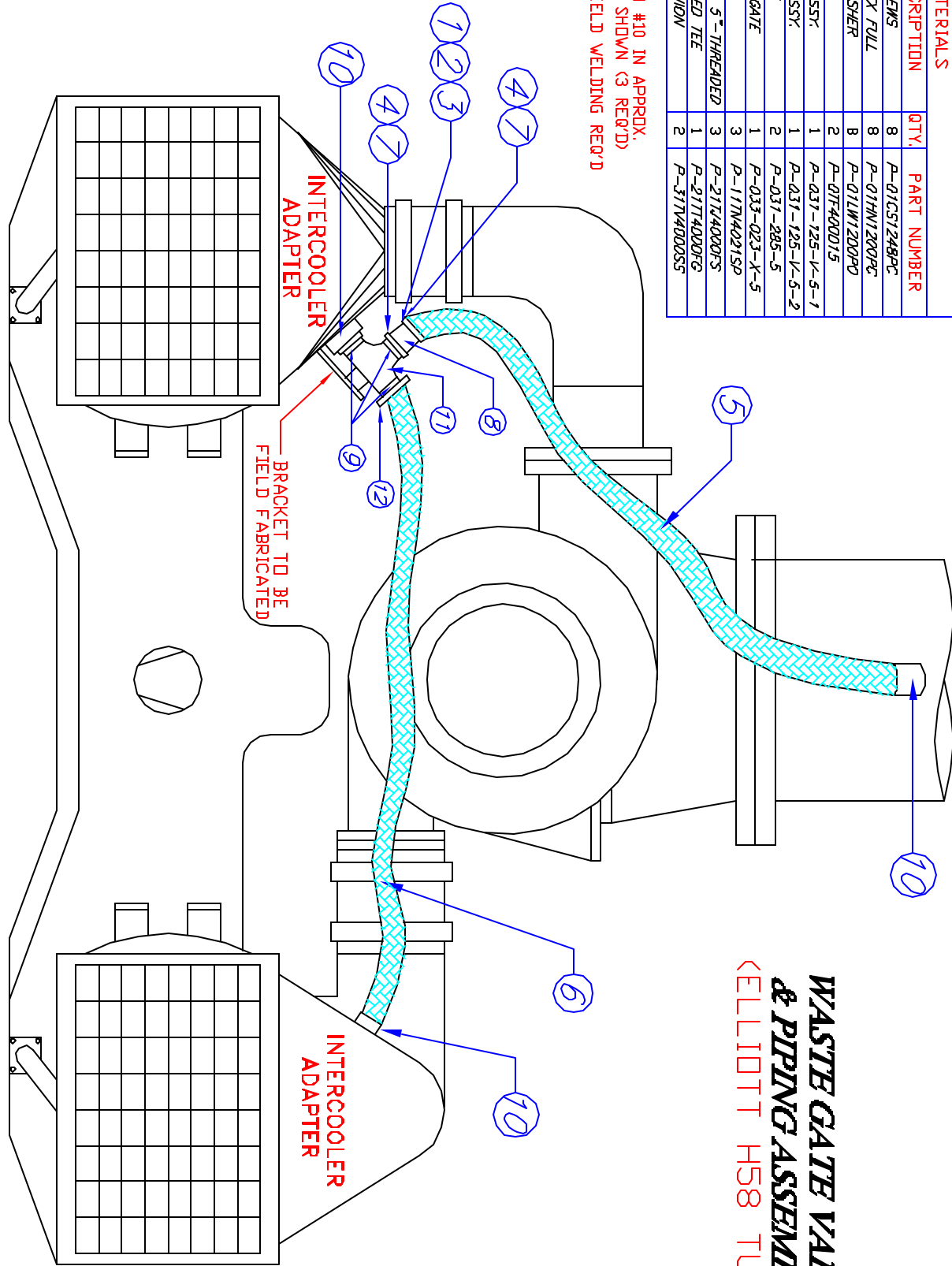

**WASTE GATE VALVE  
 & PIPING ASSEMBLY  
 <ELLIOTT H58 TURBO>**

**ENDYn**  
The Power to  
 Run Smarter  
 Plants

300 WEST FIRST + ALICE TEXAS 78132 USA

TITLE  
**WASTE GATE & PIPING KIT**

MATERIAL  
**SEE B.O.M.**

APPROVED BY  
**JC**

DATE  
**4/24/00**

DRAWN BY  
**JC**

DRAWING NUMBER  
**P-033-023-V-5**

THIS PRINT IS PROVIDED ON A RESTRICTED BASIS. NOT TO BE USED IN ANY WAY DETRIMENTAL TO THE INTEREST OF ENDYN.

ITEM	QTY	P/N	DESCRIPTION
1	2	P-21TJ2400FS	COLLARS
2	1	P-08WF2400IS	FLANGE
3	4	P-01CS1236PC	CAPSCREWS
4	4	P-01LW1000PD	LOCKWASHERS
5	4	P-01HN1000PC	HEX NUTS
6	1	P-01TF2400IS	FLANGE
7	2	P-11TN2421SP	NIPPLES (CLOSE)
8	1	P-31TV2400SS	HEX UNION
9	1	P-11TE2400MA	90° ELBDW
10	1	P-031-125-X	HOSE
11	1	P-033-023-X-3	WASTE GATE
12	2	P-031-126	GASKETS

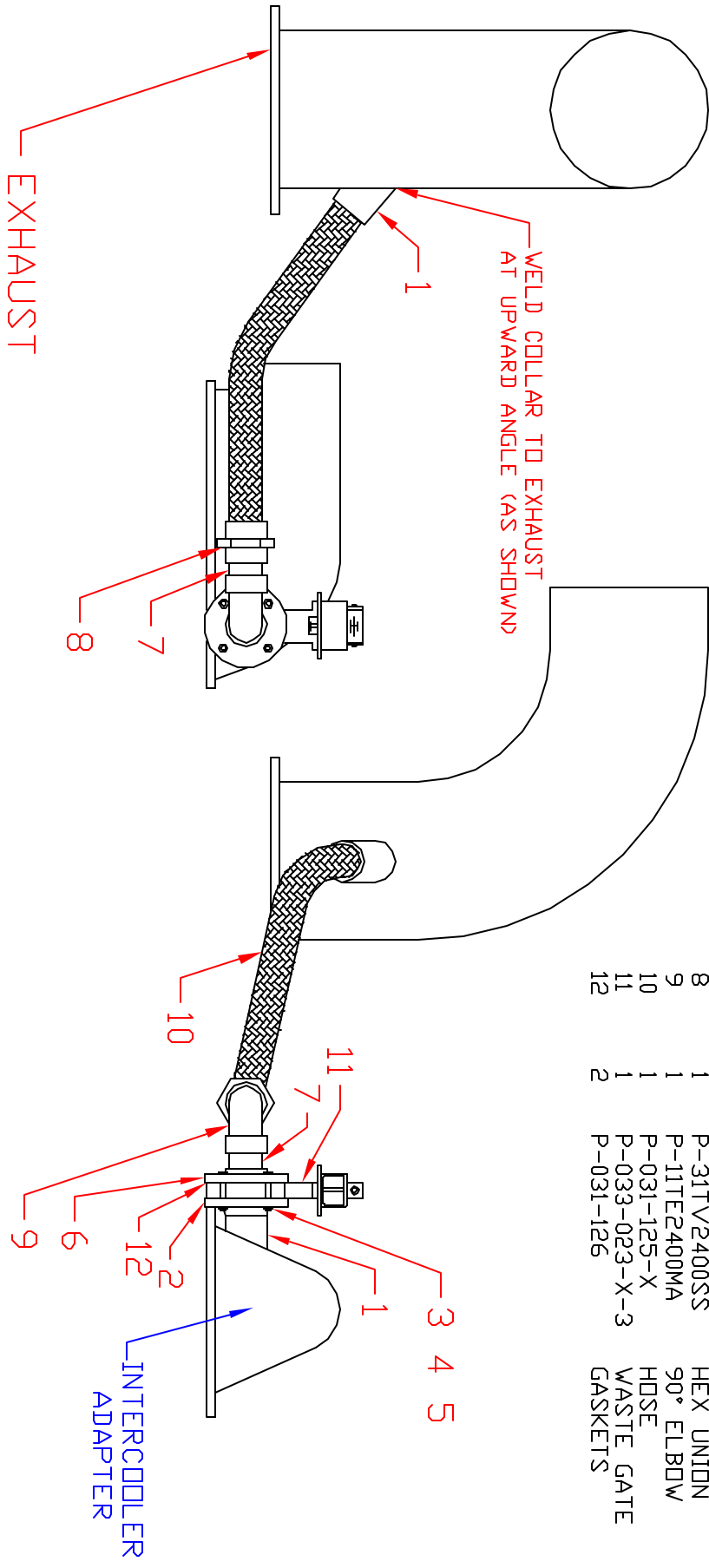

- NOTES:
- WELD ITEM #1 IN APPROX. POSITIONS SHOWN (2 REQ'D)
  - WELD #2 TO #1
  - MINIMAL FIELD WELDING REQ'D

REV.4

<b>TITLE</b> WASTE GATE & PIPING KIT	
<b>MATERIAL</b> SEE B.O.M.	
APPROVED BY JJC	DATE 4/24/00
DRAWING NUMBER P-033-023-Y-3	

THIS PRINT IS PROVIDED ON A RESTRICTED BASIS. NOT TO BE USED IN ANY WAY DETRIMENTAL TO THE INTEREST OF ENDYNN.

ITEM	QTY	P/N	DESCRIPTION
1	2	P-21TJ3200FS	COLLARS
2	1	P-08WF320015	FLANGE
3	4	P-01CS1236PC	CAPSCREWS
4	4	P-01LW1000PD	LOCKWASHERS
5	4	P-01HN1000PC	HEX NUTS
6	1	P-01TF320015	FLANGE
7	2	P-11TN3221SP	NIPPLES (CLOSE)
8	1	P-31TV3200SS	HEX UNION
9	1	P-11TE3200MA	90° ELBOW
10	1	P-031-125-X-4	HOSE
11	1	P-033-023-X-4	WASTE GATE
12	2	P-031-285	GASKETS

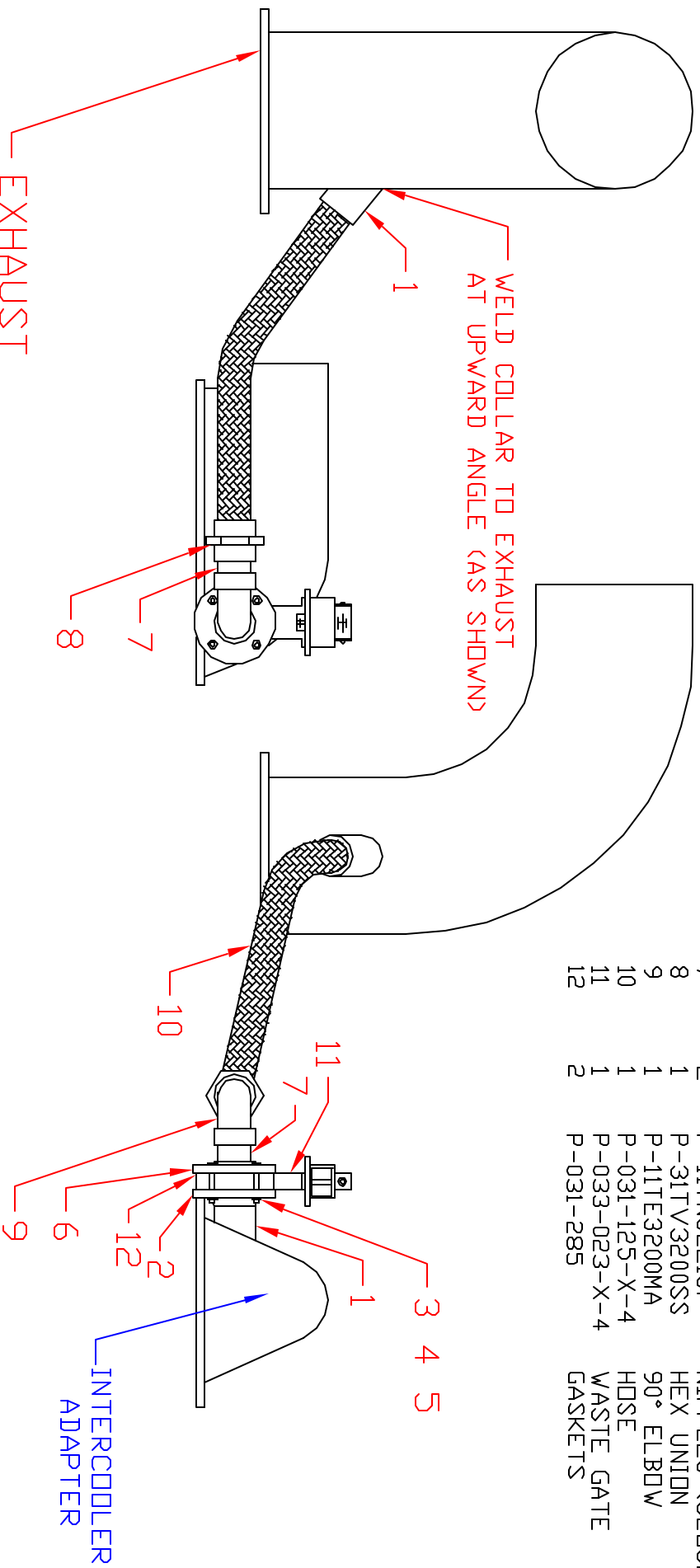

WELD COLLAR TO EXHAUST AT UPWARD ANGLE (AS SHOWN)

EXHAUST

INTERCOOLER ADAPTER

- NOTES:
- WELD ITEM #1 IN APPROX. POSITIONS SHOWN (2 REQ'D)
  - WELD #2 TO #1
  - MINIMAL FIELD WELDING REQ'D

REV.2

The Above  
Is Not  
To Be  
Used  
Without  
The  
Approval  
Of  
Endyn

300 WEST FIRST + ALICE TEXAS 76132 USA

**ENDYN**

300 WEST FIRST + ALICE TEXAS 76132 USA

---

THIS PRINT IS PROVIDED ON A RESTRICTED BASIS. NOT TO BE USED IN ANY WAY DETRIMENTAL TO THE INTEREST OF ENDYN.

DRAWN BY: JC

APPROVED BY: JC

DATE: 4/24/00

---

MATERIAL: SEE B.O.M.

---

TITLE: WASTE GATE & PIPING KIT

---

DRAWING NUMBER: P-033-023-Y-4